

# WXF15.400

Lavoce

## 15" WOOFER

FERRITE MAGNET  
ALUMINIUM BASKET DRIVER

- 3 INCH CCAW VOICE COIL
- 99,5 dB/SPL SENSITIVITY
- 800 WATT PROGRAM POWER HANDLING
- FEM OPTIMIZED MOTOR AND SUSPENSIONS
- OPTIMIZED COOLING SYSTEM
- TRIPLE ROLL SURROUND

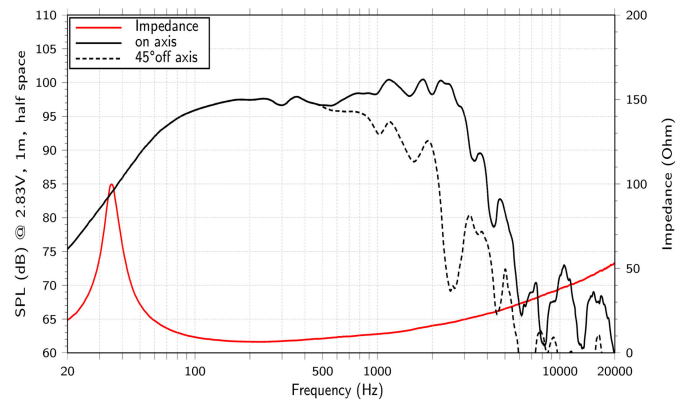

### GENERAL SPECIFICATIONS

Nominal Diameter	<b>380 mm (15 in)</b>
Nominal Impedance	<b>8 ohm</b>
Minimum Impedance	<b>6.5 ohm</b>
Program Power	<b>800 W</b> Program power is defined as 3 dB greater than AES Power.
AES Power Rating	<b>400 W</b> Tested for two hours using a continuous, band-limited pink noise signal as per AES 2-1984 Rev. 2003. Loudspeaker tested in free air.
Sensitivity	<b>99.5 dB</b> From T/S parameters, measured with Klippel DA LPM module.
Frequency Range	<b>50 ÷ 3000 Hz</b>
Voice Coil Diameter	<b>75 mm (3 in)</b>
Chassis Material	<b>ALUMINIUM</b>
Magnet Material	<b>FERRITE</b>
Magnet Dimensions OD x ID x h	<b>190 x 82 x 20 mm (7.48 x 3.23 x 0.79 in)</b>
Coil Material	<b>CCA W</b>
Former Material	<b>GLASS FIBER</b>
Cone Material	<b>WATER RESISTANT TREATED PAPER</b>
Surround Material	<b>POLYCOTTON</b>
Xmax	<b>5.2 mm (0.2 in)</b> The Xmax is calculated as: $(Hvc - Hg) / 2 + Hg / 4$ . Hvc is the voice coil height and Hg the gap height.
Xmech	<b>10.7 mm (0.42 in)</b> The Xmech is calculated as: $(Hvc - Hg) / 2 + (Hg - 2)$ . Hvc is the voice coil height and Hg the gap height.
Gap Height	<b>10 mm (0.39 in)</b>
Voice Coil Winding Height	<b>15.5 mm (0.61 in)</b>
Driver Displacement Volume	<b>4.26 l (0.15 ft³)</b>
Recommended Enclosure	<b>84.9 l (2.998 ft³)</b>
Recommended Tuning	<b>60 Hz</b>

### SMALL SIGNAL PARAMETERS

Thiele-Small parameters are measured after preconditioning: a) at 20°C- 22°C, 50% humidity for 2 hours; b) by Klippel LSI measurement.

DC Resistance (Re)	<b>5.6 ohm</b>
Diaphragm Area (Sd)	<b>855 cm² (132.525 in²)</b>

Resonance Frequency (Fs)	44 Hz
Moving Mass (Mms)	78.9 g (2.783 oz)
Compliance (Cms)	0.164 mm/N
Force Factor (BxL)	18.92 N/A
Mechanical Q-Factor (Qms)	3.55
Electrical Q-Factor (Qes)	0.34
Total Q-Factor (Qts)	0.31
Equivalent Air Volume (Vas)	170.04 l (6.005 ft³)
Voice Coil Inductance (Le)	0.84 mH
Reference Efficiency (Eta 0)	4.09 %
Efficiency Bandwidth Product (EBP)	129 Hz

## DIMENSIONS

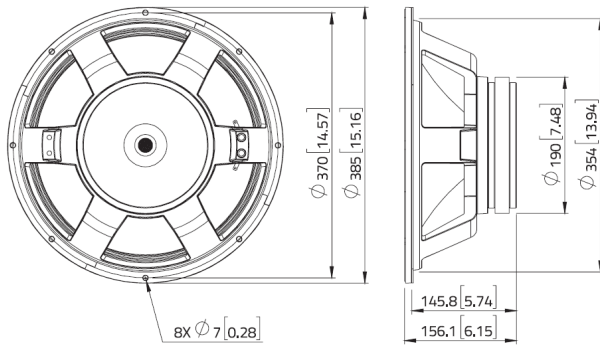

## SHIPPING INFORMATION

Net Weight	8 kg (17.637 lb)
Multipack Quantity	1
Multipack size W x D x H	422 mm x 422 mm x 206 mm (16.6 in x 16.6 in x 8.1 in)
Multipack Weight	9.59 kg (21.14 lb)

## REPAIR KITS

LF Repair Kit	VRK99152
---------------	----------

